

SUPERSEAL

Brushstrip in carrier

90° standard range

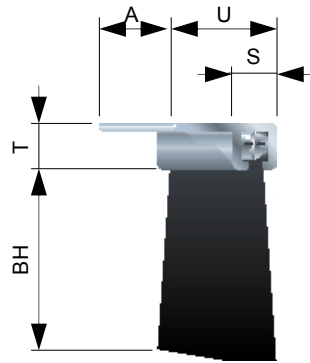

Superseal is manufactured in hardwearing nylon filament fitted with a durable mill finish aluminium carrier.

Features

- Eight nominal section sizes
- 2m, 2.5m and 3m standard lengths
- Brush heights up to 213mm
- Modified lengths, brush heights and finishes available on request

Light duty

Type	Carrier dimensions			Brush height BH	Fill material	Part number		
	S	T	U			2m length	2.5m length	3m length
M	3.70	4.00	13.00	10.00	Nylon black 0.10	H610MT2013	H610MT2513	H610MT3013
				15.00	Nylon black 0.15	H610MT2018	H610MT2518	H610MT3018
A	5.20	5.60	14.00	10.00	Nylon black 0.15	H610AT2014	H610AT2514	H610AT3014
				15.00	Nylon black 0.15	H610AT2019	H610AT2519	H610AT3019
B	6.50	6.70	17.50	13.50	Nylon black 0.15	H610BT2019	H610BT2519	H610BT3019
				19.00	Nylon black 0.15	H610BT2025	H610BT2525	H610BT3025
				26.00	Nylon black 0.15	H610BT2032	H610BT2532	H610BT3032
				38.00	Nylon black 0.15	H610BT2044	H610BT2544	H610BT3044

Medium duty

Type	Carrier dimensions			Brush height BH	Fill material	Part number		
	S	T	U			2m length	2.5m length	3m length
C	7.70	8.40	22.00	15.00	Nylon black 0.15	H610CT2022	H610CT2522	H610CT3022
				25.00	Nylon black 0.15	H610CT2032	H610CT2532	H610CT3032
				35.00	Nylon black 0.20	H610CT2042	H610CT2542	H610CT3042
				50.00	Nylon black 0.20	H610CT2057	H610CT2557	H610CT3057
D	10.00	10.80	27.00	12.00	Nylon black 0.20	H610DT2019	H610DT2519	H610DT3019
				19.00	Nylon black 0.20	H610DT2025	H610DT2525	H610DT3025
				26.00	Nylon black 0.20	H610DT2032	H610DT2532	H610DT3032
				30.00	Nylon black 0.20	H610DT2038	H610DT2538	H610DT3038
				40.00	Nylon black 0.20	H610DT2048	H610DT2548	H610DT3048
				49.00	Nylon black 0.20	H610DT2057	H610DT2557	H610DT3057
E	10.50	11.80	29.00	75.00	Nylon black 0.30	H610DT2083	H610DT2583	H610DT3083
				41.00	Nylon black 0.30	H610ET2051	H610ET2551	H610ET3051
				50.00	Nylon black 0.30	H610ET2060	H610ET2560	H610ET3060
				66.00	Nylon black 0.30	H610ET2076	H610ET2576	H610ET3076
				75.00	Nylon black 0.30	H610ET2085	H610ET2585	H610ET3085
				100.00	Nylon black 0.40	H610ET2110	H610ET2510	H610ET3110



Kleeneze Sealtech Limited
Ansteys Road
Hanham
Bristol
BS15 3SS
UK

T: +44 (0)117 958 2450
F: +44 (0)117 960 0141
E: sales@ksltd.uk.com
www.ksltd.com

SUPERSEAL

Brushstrip in carrier

90° standard range

Heavy duty

Type	Carrier dimensions			Brush height	Fill material	Part number		
	S	T	U	BH		2m length	2.5m length	3m length
G	13.50	14.50	35.00	45.00	Nylon black 0.50	H610GT2057	H610GT2557	H610GT3057
				64.00	Nylon black 0.30	H610GT2076	H610GT2576	H610GT3076
				102.00	Nylon black 0.50	H610GT2114	H610GT2514	H610GT3114
				150.00	Nylon black 0.50	H610GT2162	H610GT2562	H610GT3162
H	17.90	18.10	68.00	213.00	Nylon black 0.90	H610HT2229	H610HT2529	H610HT3229

All dimensions are in mm

How to specify

Select required brush height (BH) and thickness according to the size of gap to be sealed.

For modified products, select the standard part number and specify:

- ▶ Modified length (A)
- ▶ Brush height (BH)

Technical notes

Cutting to length

Superseal should be removed from the aluminium carrier and cut to length with side action croppers to ensure the ends are completely resealed and avoid spillage of the filaments.

Aluminium carriers should be cut with a fine tooth saw and deburred. File a lead-in at one end of the carrier to aid assembly of the brushstrip.

Fitting

Superseal products should be fitted with the tips of the filaments in firm contact with the mating surface but barely flexed. Fixings should be positioned within 50mm of each end and at 300mm centres thereafter.

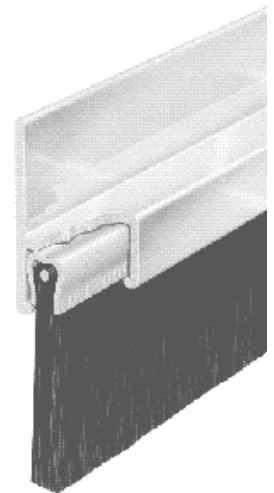

Superseal brushstrip is available in either 180°, 45° or 90° aluminum carriers



Kleeneze Sealtech Limited
 Ansteys Road
 Hanham
 Bristol
 BS15 3SS
 UK

T: +44 (0)117 958 2450
 F: +44 (0)117 960 0141
 E: sales@ksltd.uk.com
 www.ksltd.com

Buy online



▶ Stock items normally despatched next day
 Modified items within 5 days.