

KEZSTRIP

Brushstrip in carrier

Special manufacture 90° carrier

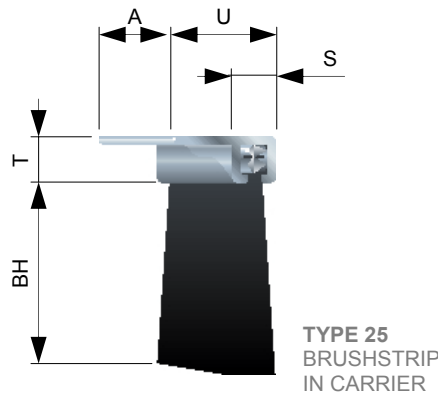

Manufactured to customer specification, a range of fill materials including synthetic, wire and natural is available to suit all applications. Carriers can be provided with fixing slots, machined features, anodised or painted finishes.

Features

- Durable aluminium carriers
- Electroplated mild steel, stainless or aluminium backing tape
- Fill materials to suit all applications
- Straight or profiled trims

Light duty

BRUSHSTRIP DIMENSIONS AND TOLERANCES							FILL MATERIALS					
Section code	Carrier code	Carrier dimensions			Overall length	Brush height	Synthetic		Steel wire		Phos Bronze Ni Silver Brass	
		S	T	U			A Max	BH Max	Min	Max	Min	Max
M1	EA082	3.70	4.00	13.00	3000.00	34.00	0.06	0.20	0.06	0.06	0.06	0.06
M2	EA082	3.70	4.00	13.00	3000.00	34.00	0.06	0.20	0.06	0.06	0.06	0.06
A1	EA058	5.20	5.60	14.00	3000.00	34.00	0.06	0.25	0.06	0.11	0.06	0.13
A2	EA058	5.20	5.60	14.00	3000.00	34.00	0.06	0.25	0.06	0.11	0.06	0.13
A4	EA058	5.20	5.60	14.00	3000.00	34.00	0.06	0.20				
B1	EA054	6.50	6.70	17.50	3000.00	112.00	0.06	0.35	0.06	0.13	0.06	0.19
B2	EA054	6.50	6.70	17.50	3000.00	112.00	0.06	0.35	0.06	0.13	0.06	0.19
B4	EA054	6.50	6.70	17.50	3000.00	112.00	0.06	0.25				

Medium duty

BRUSHSTRIP DIMENSIONS AND TOLERANCES							FILL MATERIALS					
Section code	Carrier code	Carrier dimensions			Overall length	Brush height	Synthetic		Steel wire		Phos Bronze Ni Silver	
		S	T	U			A Max	BH Max	Min	Max	Min	Max
C1	EA.61	7.70	8.40	18.70	3000.00	122.00	0.06	0.40	0.06	0.19	0.06	0.25
C2	EA061	7.70	8.40	18.70	3000.00	122.00	0.06	0.40	0.06	0.19	0.06	0.25
D1	EA052	10.00	11.20	27.00	3000.00	125.00	0.06	0.50	0.06	0.25	0.06	0.29
D2	EA052	10.00	11.20	27.00	3000.00	125.00	0.06	0.50	0.06	0.25	0.06	0.29
E1	EA057	10.50	11.80	29.00	3000.00	125.00	0.06	0.60	0.06	0.29	0.06	0.34
E2	EA057	10.50	11.80	29.00	3000.00	125.00	0.06	0.60	0.06	0.29	0.06	0.34

Continued on page 2



Kleeneze Sealtech Limited
Ansteys Road
Hanham
Bristol
BS15 3SS
UK

T: +44 (0)117 958 2450
F: +44 (0)117 960 0141
E: sales@ksltd.uk.com
www.ksltd.com

KEZSTRIP

Brushstrip in carrier

Special manufacture 90° carrier

Heavy duty

BRUSHSTRIP DIMENSIONS AND TOLERANCES							FILL MATERIALS					
Section code	Carrier code	Carrier dimensions			Overall length	Brush height	Synthetic		Steel wire		Phos Bronze Ni Silver Brass	
		S	T	U			A Max	BH Max	Min	Max	Min	Max
G1	EA035	13.50	14.50	35.00	3000.00	145.00	0.06	0.90	0.06	0.34	0.06	0.46
G2	EA035	13.50	14.50	35.00	3000.00	145.00	0.06	0.90	0.06	0.34	0.06	0.46
H1	EA079	17.90	18.10	68.00	3000.00	280.00	0.06	2.00	0.06	0.46	0.06	0.56
H2	EA079	17.90	18.10	68.00	3000.00	280.00	0.06	2.00	0.06	0.46	0.06	0.56

Section code

Nominal size: M to H

1: Electroplated mild steel, 2: Stainless steel, 4: Aluminium

Dimensions are in mm

How to specify Type 25 Brushstrip in carrier

Specify the following together with any additional requirements according to your application:

- ▶ Section code
- ▶ Fill material
- ▶ Length (A)
- ▶ Brush height (BH)
- ▶ Carrier code and finish



Cable management

Technical notes

Fill materials

To ensure best performance, the selection of the fill material is of paramount importance. Characteristics such as bend recovery, resistance to abrasion and chemicals are available on request. Minimum orders may apply on certain materials and colours.

SYNTHETICS

NYLON - Durable general purpose filament with good bend recovery, flex life and abrasion resistance. Max temp 120°C. Available in heat stabilised grades.

NYLON CONDUCTIVE - Properties of standard Nylon with a conductive coating for anti-static applications.

NYLON FR(H) - Fire retardant Nylon with low smoke density and zero halogens.

NYLON ABRASIVE - Abrasive impregnated filament for deburring and cleaning. Good fatigue and chemical resistance. Grit size 60 - 800 (SIC) or (ALO)

POLYPROPYLENE - Good chemical resistance with less water absorption than Nylon. Max temp 60°C.

POLYESTER - Excellent filament with good stiffness, bend recovery and abrasion resistance. Particularly suitable for wet applications. Max temp 100°C

NATURAL MATERIALS

HORSEHAIR, BRISTLE, and GOAT HAIR - Excellent resistance to taking a set, good bend recovery and resistance to sunlight. Soft to medium stiffness.

METALLICS

STEEL - Crimped or flat wire.

STAINLESS STEEL - Crimped wire AISI304

PHOS BRONZE, BRASS, NI SILVER - Crimped wire

Carrier finishes

Carriers are aluminium 6063, mill finish and can be provided with all standard anodised finishes or RAL colour powder coat finishes. Minimum order values may apply on certain colours.

Cutting to length

Brushstrip should be cut to length with side action croppers to ensure the ends are completely sealed and avoid spillage of the filaments.

Aluminium carriers should be cut with a fine tooth saw and deburred. File a lead-in at one end of the carrier to aid assembly of the brushstrip.

Fitting

Brushstrip products should be fitted with the tips of the filaments in firm contact with the mating surface but barely flexed. Fixings should be positioned within 50mm of each end and at maximum 300mm centres .



Kleeneze Sealtech Limited
 Ansteys Road
 Hanham
 Bristol
 BS15 3SS
 UK

T: +44 (0)117 958 2450
 F: +44 (0)117 960 0141
 E: sales@ksltd.uk.com
 www.ksltd.com